

Fundamentals of Thermal Analysis

VAM

CEO Dr. -Ing KANG, DOHYUN

www.vamecha.com

dowajuge@gmail.com

82-(0)10-3582-7056

Feb. 19 2020

Contents

- 1. Basic components of thermal analysis**
- 2. Analogy of heat transfer and electrical circuit**
- 3. Modeling of thermal analysis for cable**
- 4. Examples of thermal analysis for cable**
- 5. Thermal analysis for motors**
- 6. Conclusion**

1. Basic components of thermal analysis

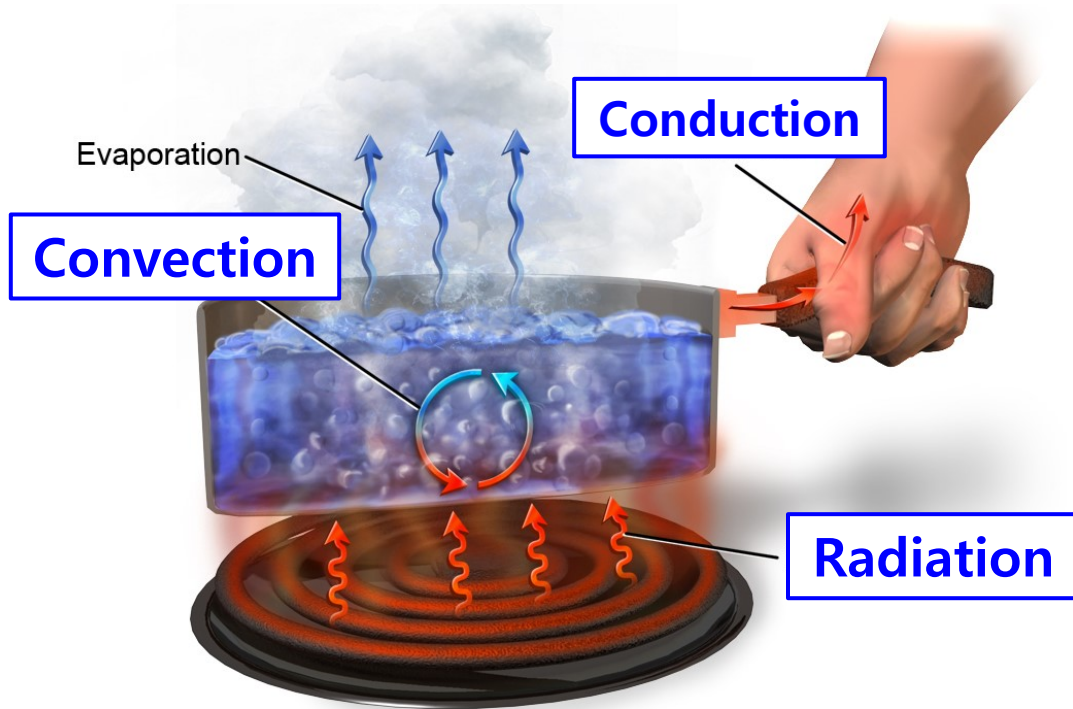

<Mechanisms of heat transfer>

- **Conduction**
Coefficient of thermal resistance in a solid
- **Convection**
Coefficient of heat transfer in a fluid or a surface of a solid. (It depends on velocity, shape, and fluid)
- **Radiation**
Generated at a high temperature
(no whipping, neglected at motor thermal analysis)

2. Analogy of heat transfer and electrical circuit

Electrical circuit

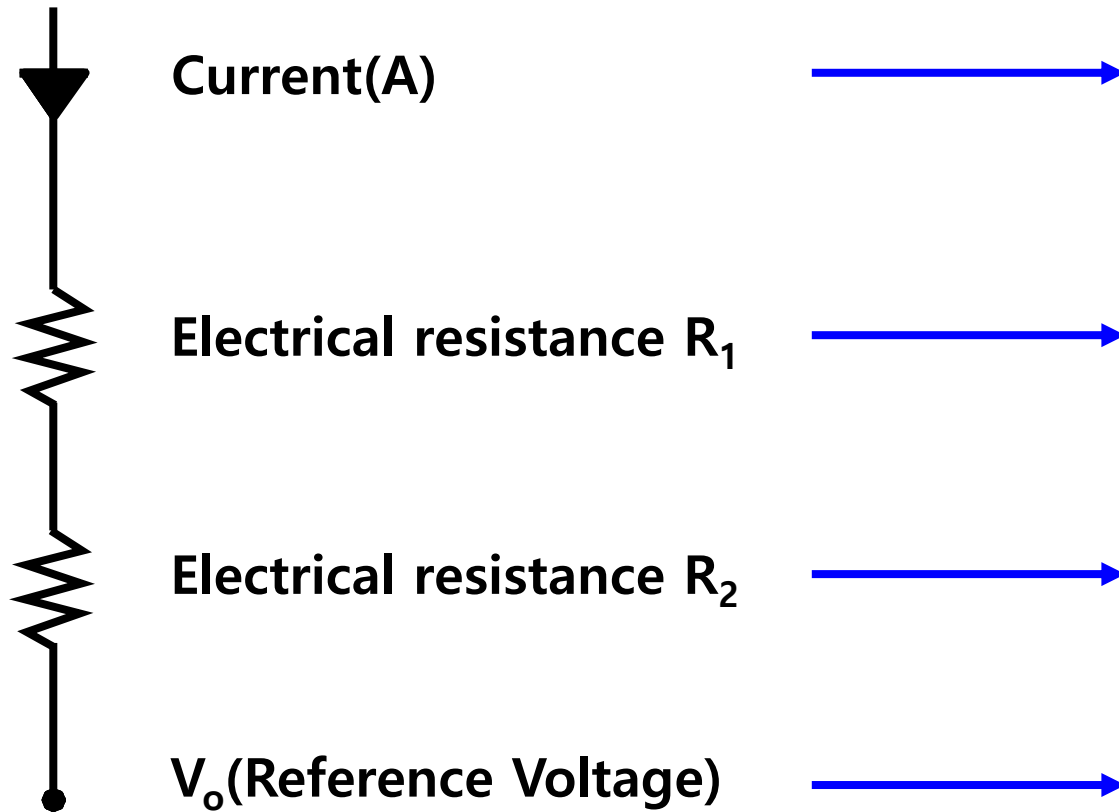

Heat transfer

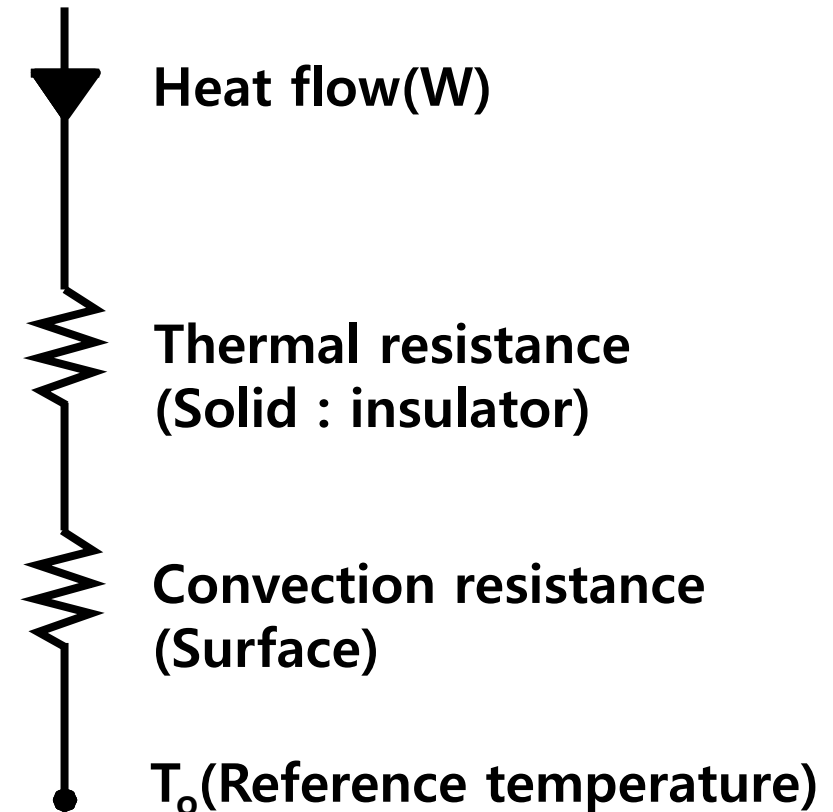

3. Modeling of thermal analysis for cable

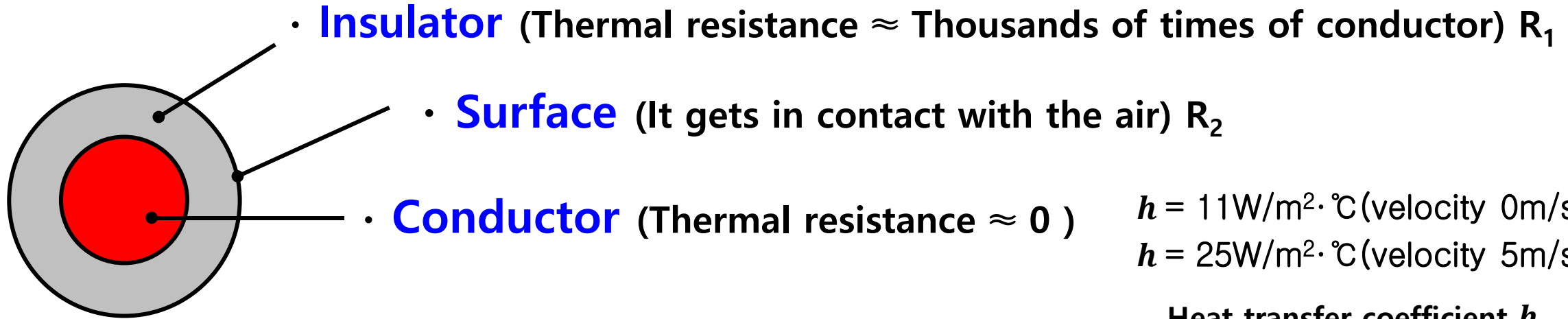

<Cross section of cable>

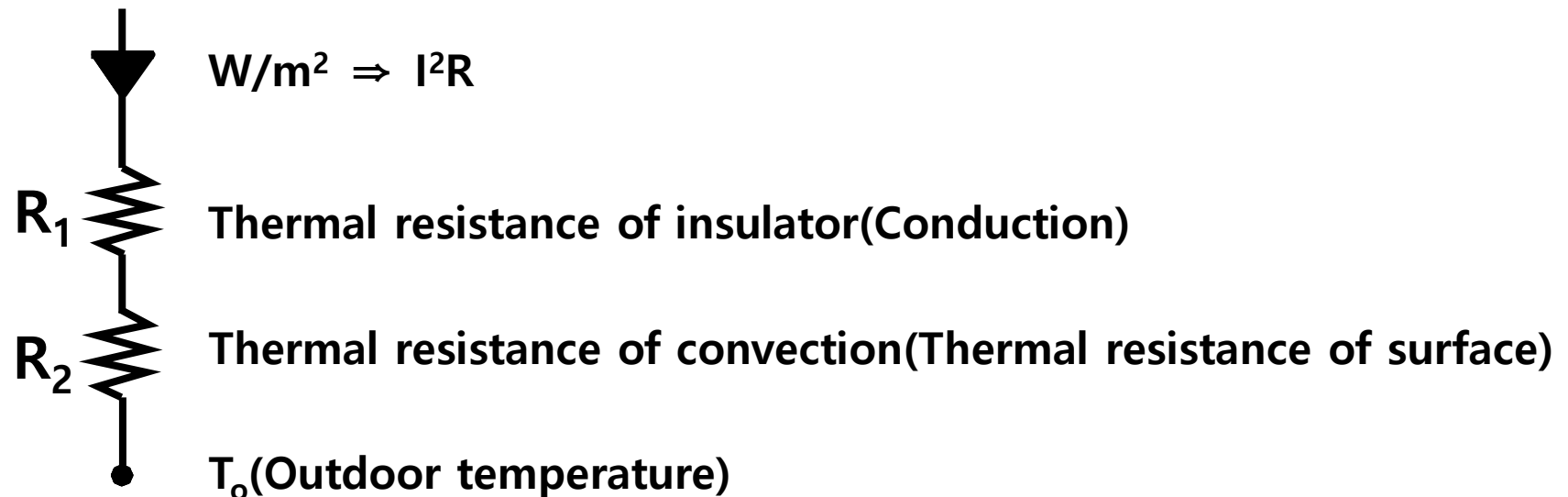

4. Examples of thermal analysis for cable

Example 4.1)

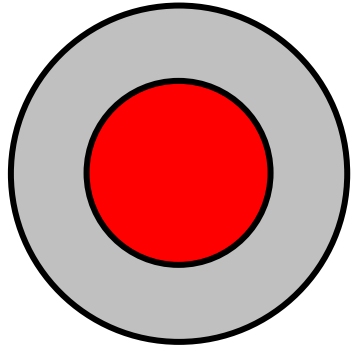

- When the current $I=100(A)$ flows in the cable and the outdoor temperature is $T_o=20^{\circ}C$, what is the highest temperature at the surface of cable and the insulator?

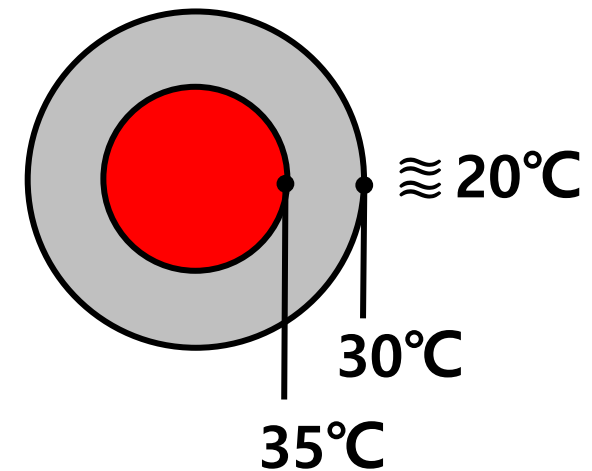
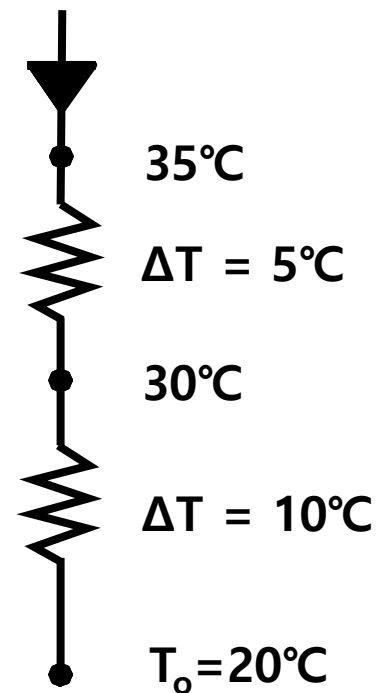
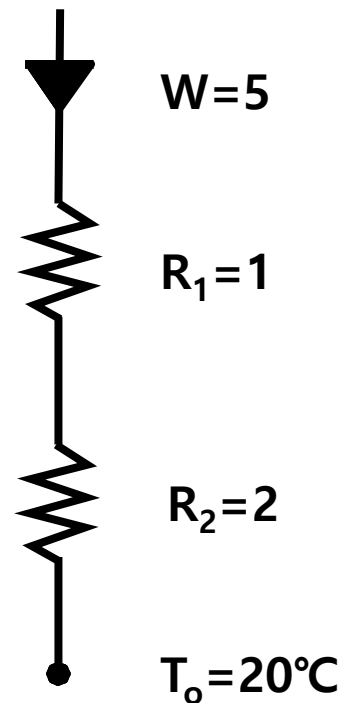

4. Examples of thermal analysis for cable

Example 4.2)

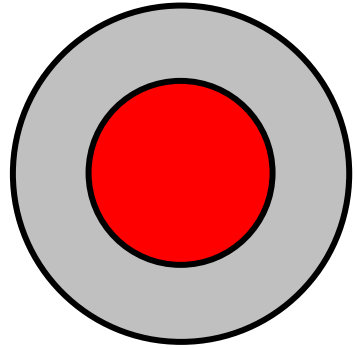

- When the current $I=200(A)$ flows in the cable and the outdoor temperature is $T_o=20^\circ C$, what is the highest temperature at the surface of cable and the insulator?

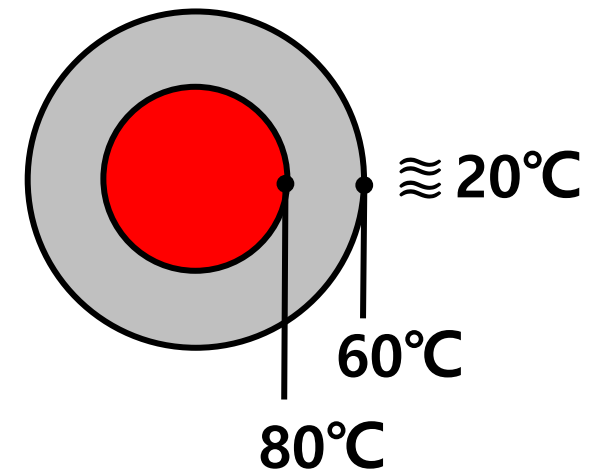
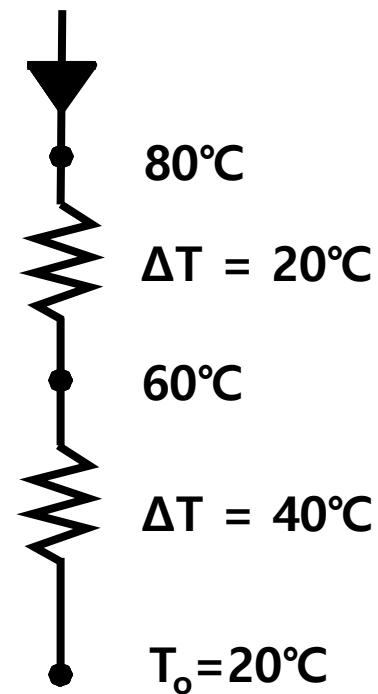
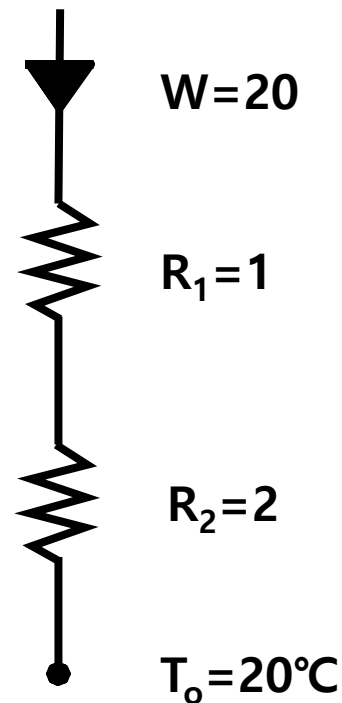

4. Examples of thermal analysis for cable

Example 4.3)

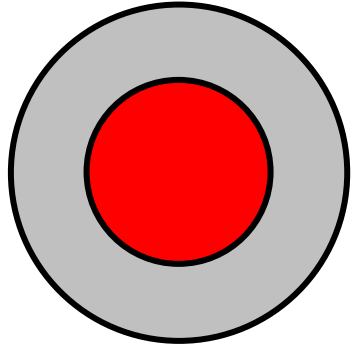

- When the current $I=100(A)$ flows in the cable and the outdoor temperature is $T_o=30^{\circ}C$, what is the highest temperature at the surface of cable and the insulator?

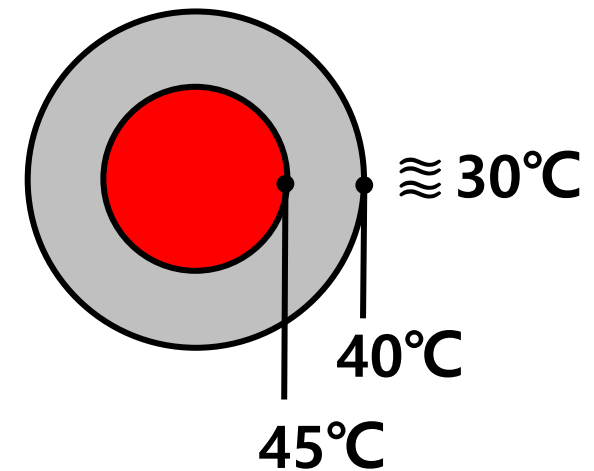
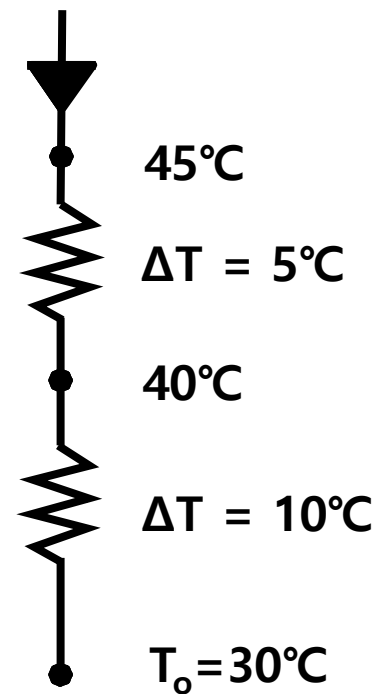
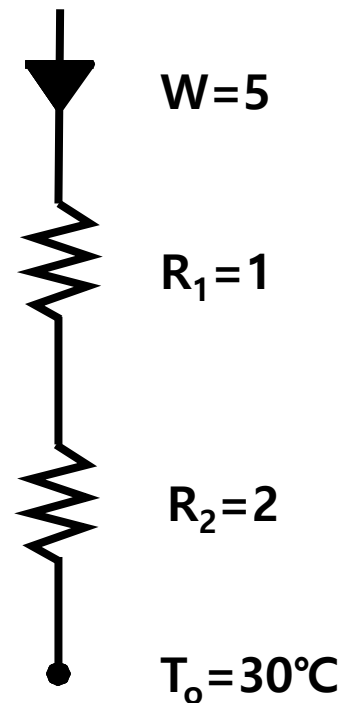

4. Examples of thermal analysis for cable

Example 4.4)

· When the current $I=100(A)$ flows in the cable, the outdoor temperature is $T_o=20^{\circ}C$, and thermal resistance of insulator is doubled in comparison with example 4.1, what is the highest temperature at the surface of cable and the insulator?

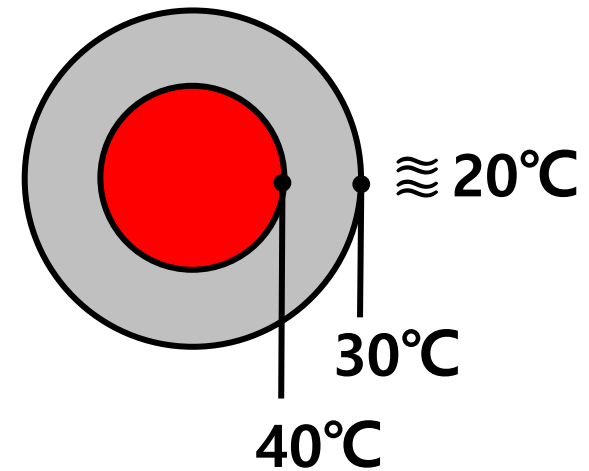
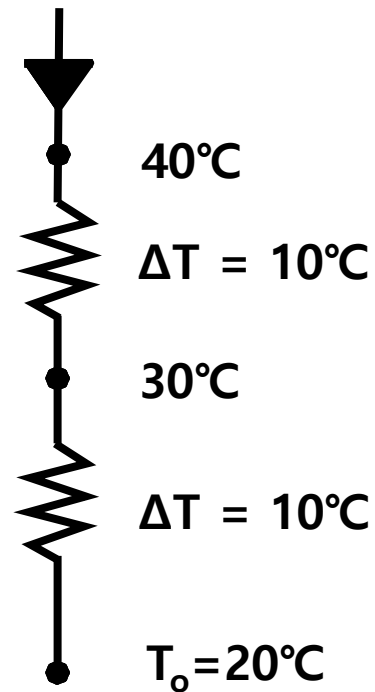
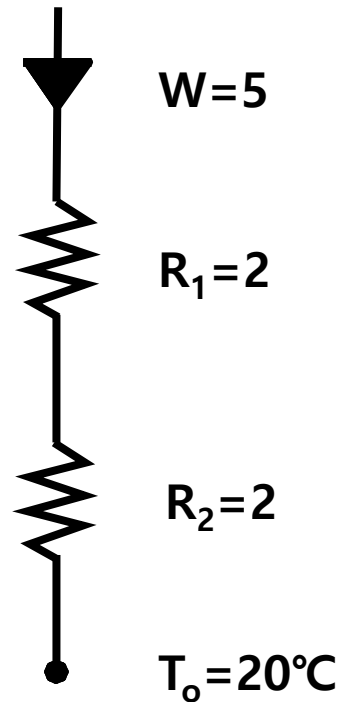
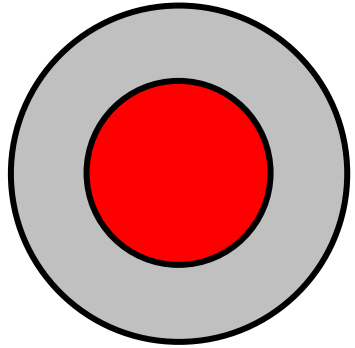

4. Examples of thermal analysis for cable

Example 4.5)

When the current $I=100(A)$ flows in the cable, the outdoor temperature is $T_o=20^{\circ}C$, and thermal resistance of convection is half in comparison with example 4.1 (A good air flow or a water cooling), what is the highest temperature at the surface of cable and the insulator?

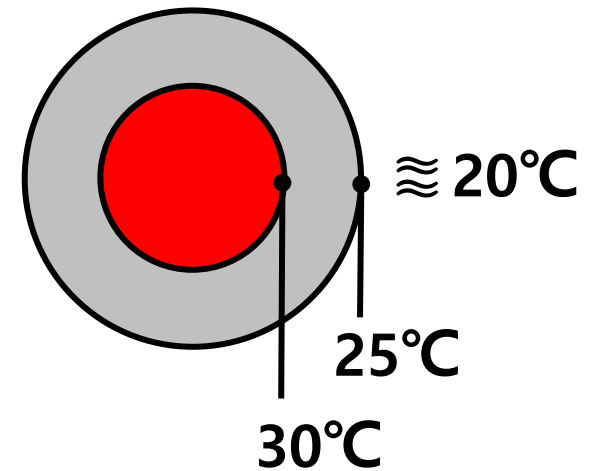
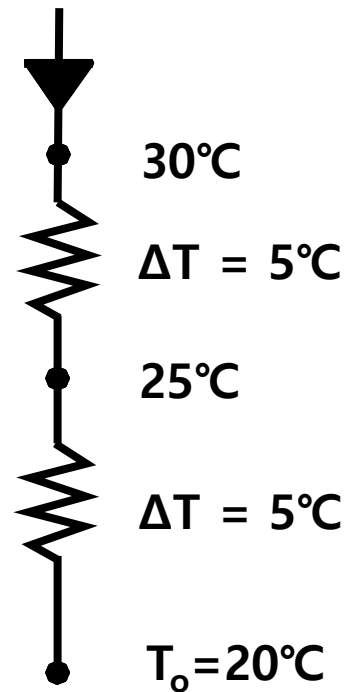
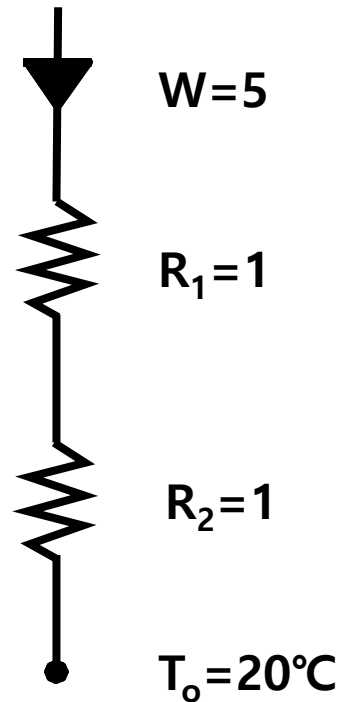
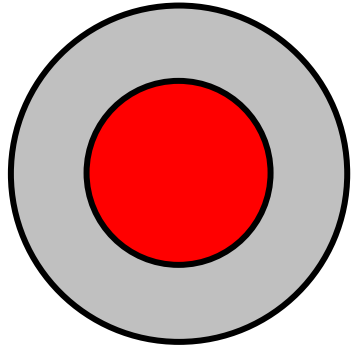

4. Examples of thermal analysis for cable

Example 4.6)

When the current $I=300(A)$ flows in the cable, the outdoor temperature is $T_o=40^\circ C$, thermal resistance of insulator is doubled, and thermal resistance of convection is half in comparison with example 4.1, what is the highest temperature at the surface of cable and the insulator?

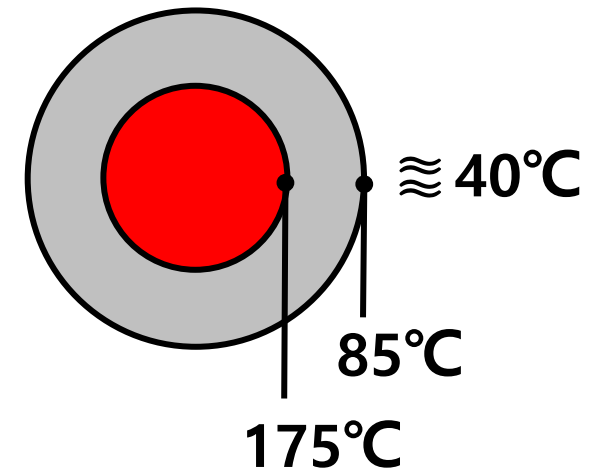
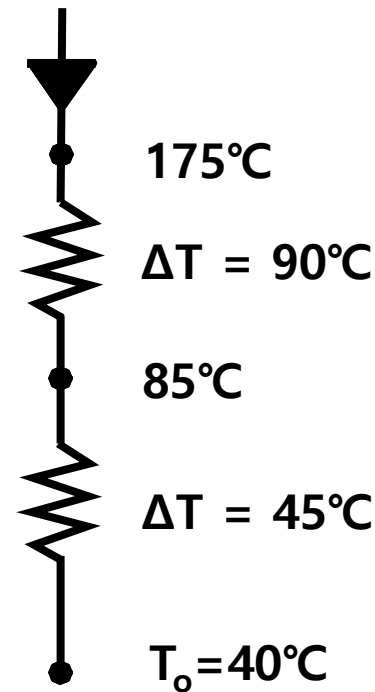
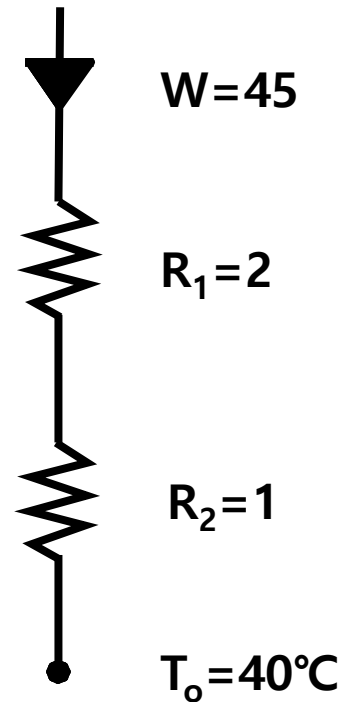
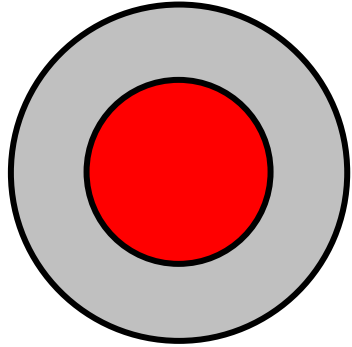

5. Thermal analysis for motors

5-1) Simplification for analysis

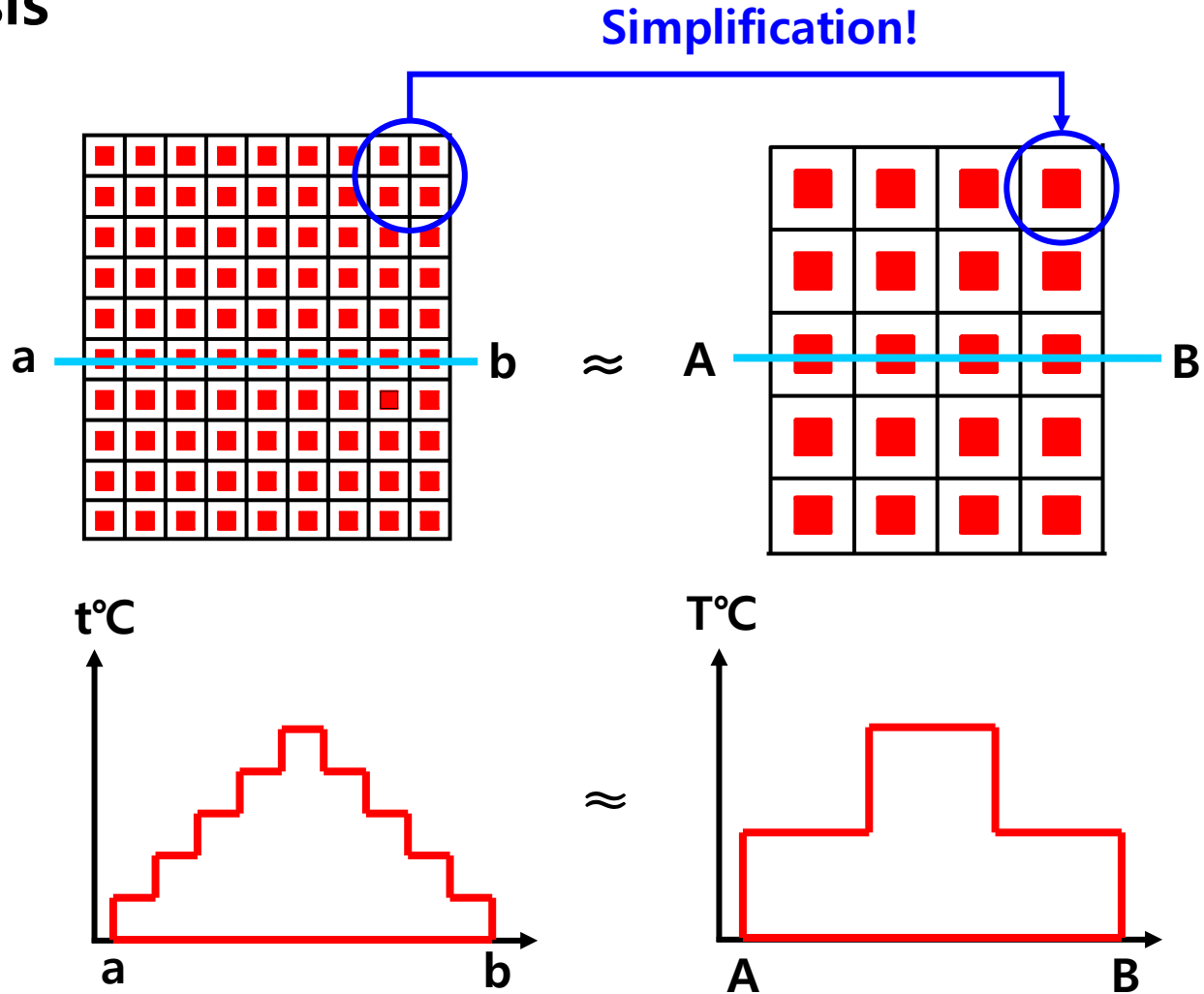
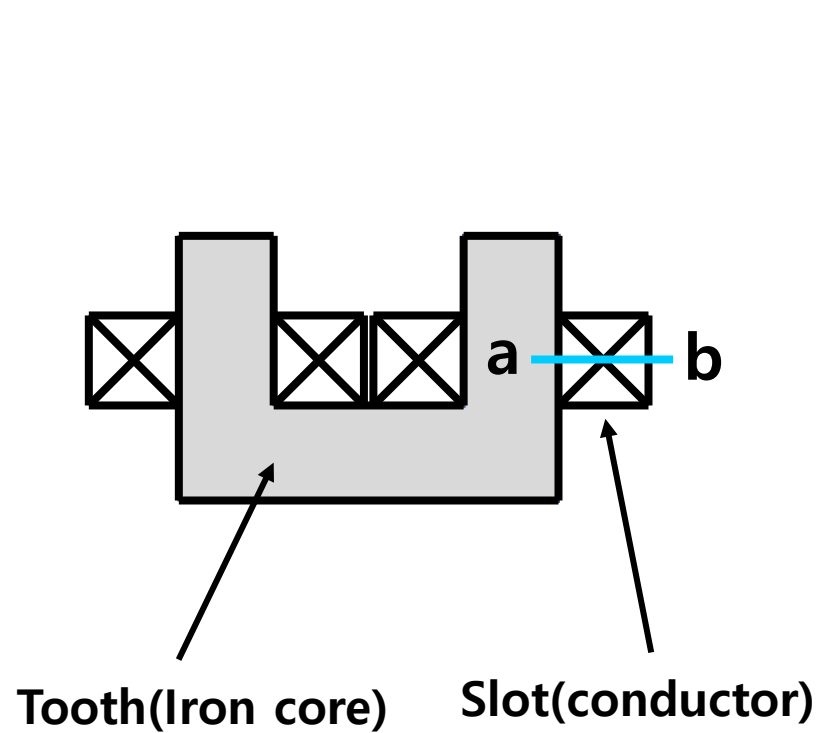

5. Thermal analysis for motors

5-2) A reason why a small motor temperature is lower than a large motor in the same current density

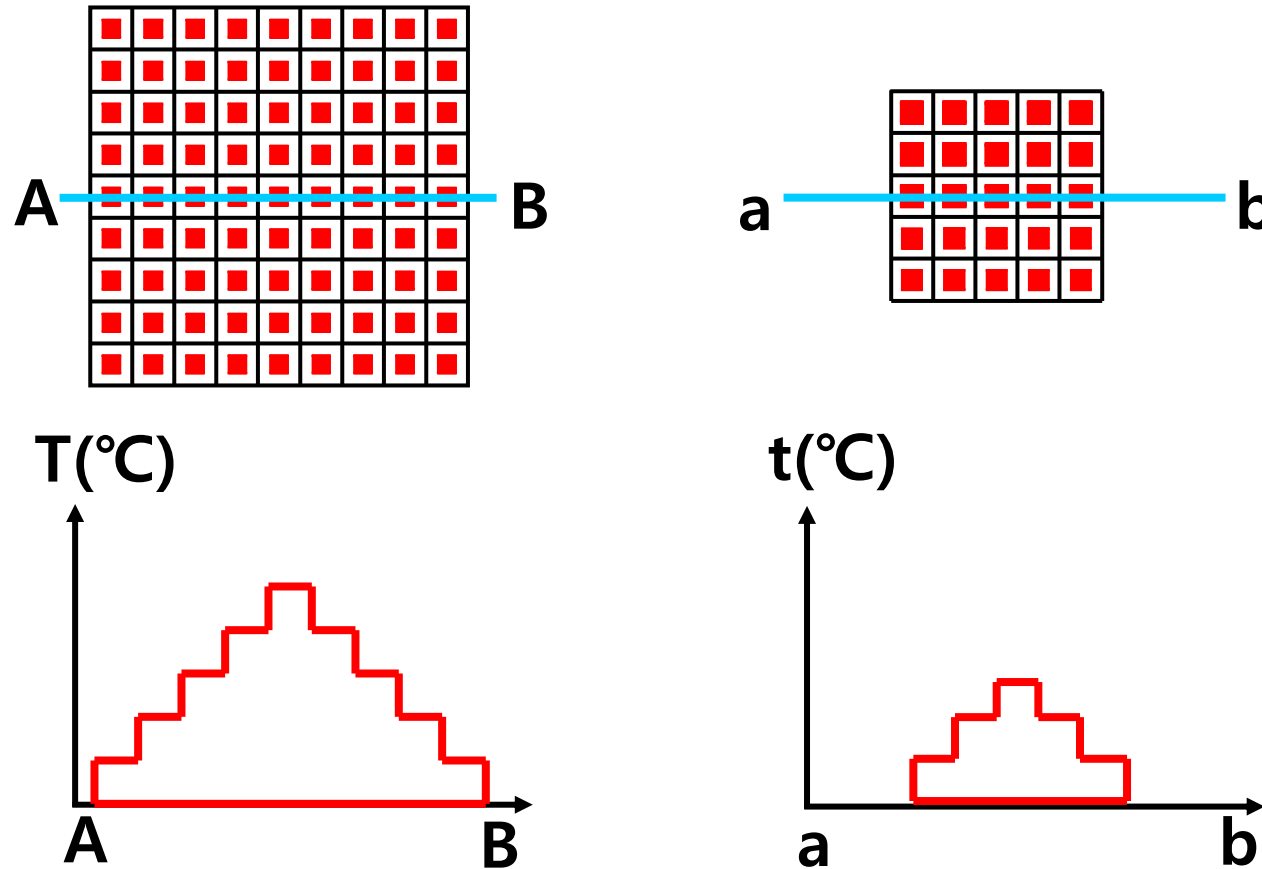

5. Thermal analysis for motors

5-3) A reason of impregnation

- A Thermal resistance of air is very high. It is 1000 times in comparison with a insulator.
- Vacuum impregnation fills a resin which lows thermal resistance at air part.

5-4) Material engineering is demanded which research subjects(eg, nano materials) that reduce a thickness and decrease thermal resistance for insulator

5-5) A reason why water cooling type is very effective.

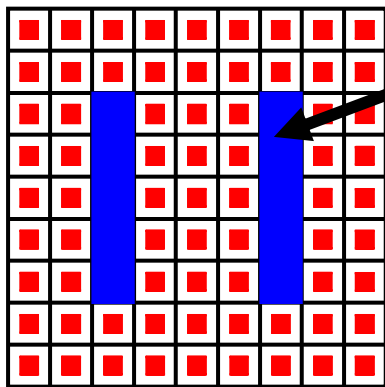

When a water cooled tube is installed between wires, it has a same temperature with water.

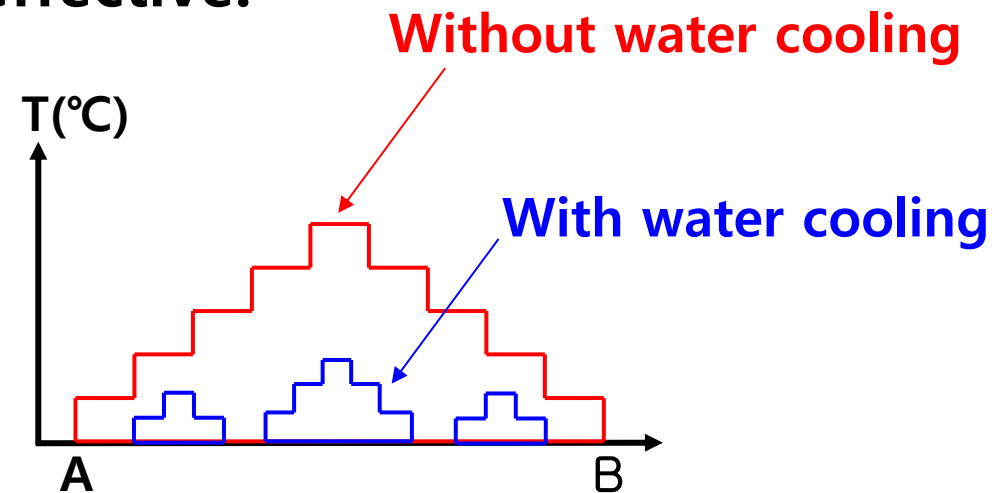

5. Thermal analysis for motors

5-6) A thermal property of transverse flux motor

- Relatively, there are many sides that contact with the air

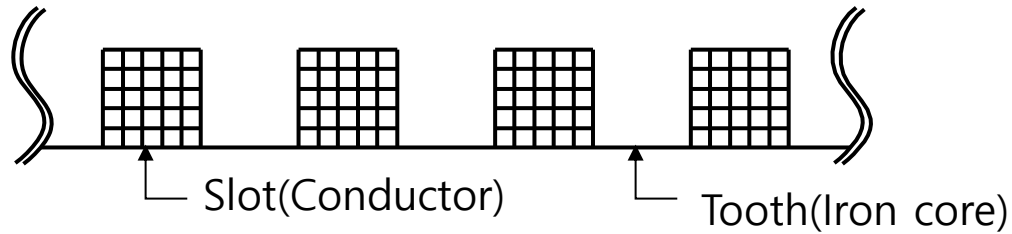

Longitudinal Flux Motor

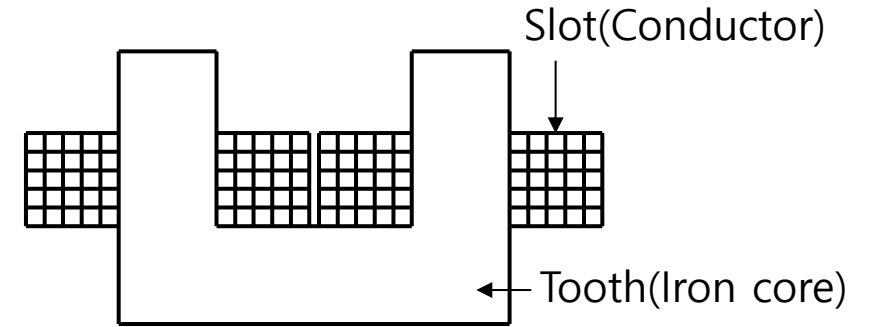

Transverse Flux Motor

- It can divide into part

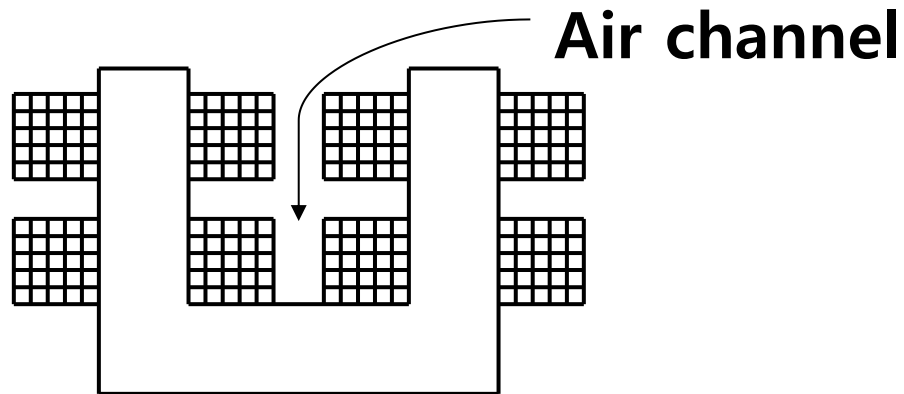

5. Thermal analysis for motors

5-7) When TFM(Thermal Finite Method)-TFE(Thermal Finite Element) are compared, the current selects with the same conditions from a temperature point.

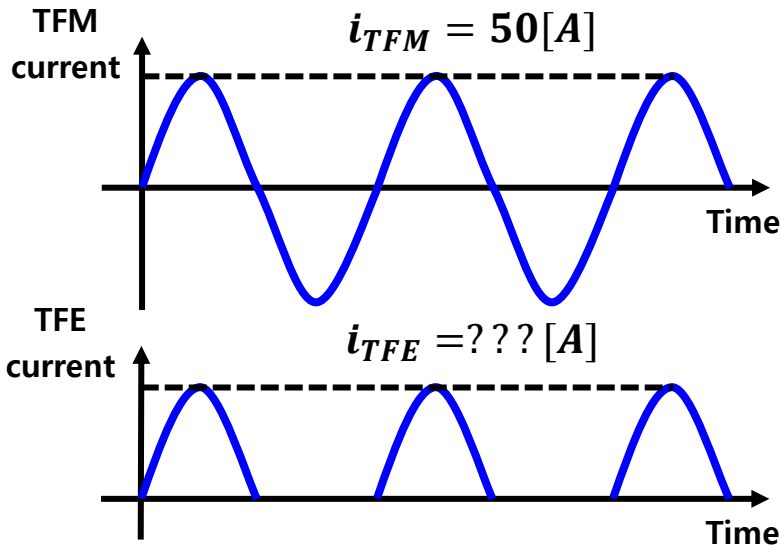

⇒ When winding resistor $R = 1[\Omega]$,

$$P = i_{TFM}^2 R = 50^2 * 1 = 2500[W]$$

⇒ For the same power in comparison with TFM,

$$P = \frac{1}{2} * i_{TFE}^2 R = 2500[W], R = 1[\Omega]$$

$$i_{TFE} = 50\sqrt{2} [A] \text{ is needed.}$$

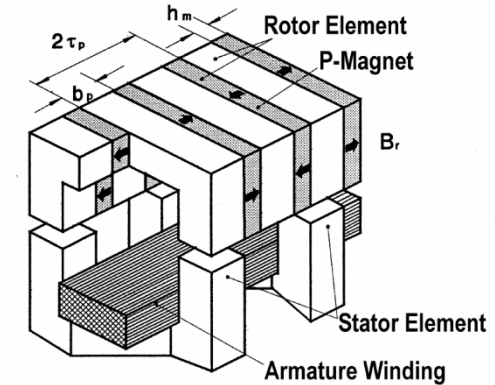

TFM

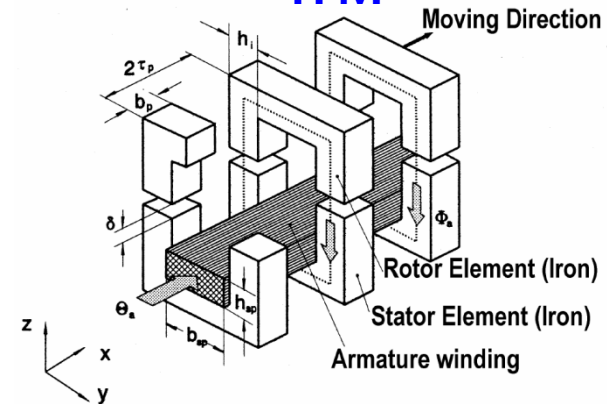

TFE

These are compared with the same temperature condition

TFM Fxd = 70kN/m² [by 50A] TFE Fxd = 10kN/m² [by 50A] TFE Fxd = 13kN/m² [by 50A X √2A]

In other words, with the same coil temperature, when TFM is 50A and TFE is 50√2[A], TFM is 70kN/m² and TFE is 13kN/m².

6. Conclusion

1. **When thermal analysis is need, the electrical circuit with the current source can be used to it.**

Current → Heat flow

Resistor → Thermal resistance

Voltage → Temperature

2. **Temperature is proportional to square of current, thermal resistance, a shape, and surface heat transfer coefficient.**

3. **The basic concept of thermal analysis is simple. But actually, a phenomenon of thermal is very complicated.**

- Surface heat transfer coefficient is considered.
- Heat source is changed as a time.
- Thermal resistance is the function of temperature.

6. Conclusion

4. For reference, power of an electric iron is 1kW approximately.

Electric charges is 100 won Korean currency(10 cent) for 1 kWh.

Additionally, power of a fan is 50W approximately. When it is used for 20 hours, power consumption is 1kWh (50W*20h).

5. How much is a power of person? (A horsepower is 736W)

If a person carries vertically 25kg of things with 1m/s speed, power of person is 245W(Force: $25\text{kg} \cdot 9.81\text{m/s}^2$ Speed: 1m/s)