

Ultra high power density Ultra high efficiency Motors & Generators

V A M

CEO Dr. -Ing KANG, DOHYUN

www.vamecha.com

dowajuge@gmail.com

82-(0)10-3582-7056

Dec. 15 2020

1. Benefit

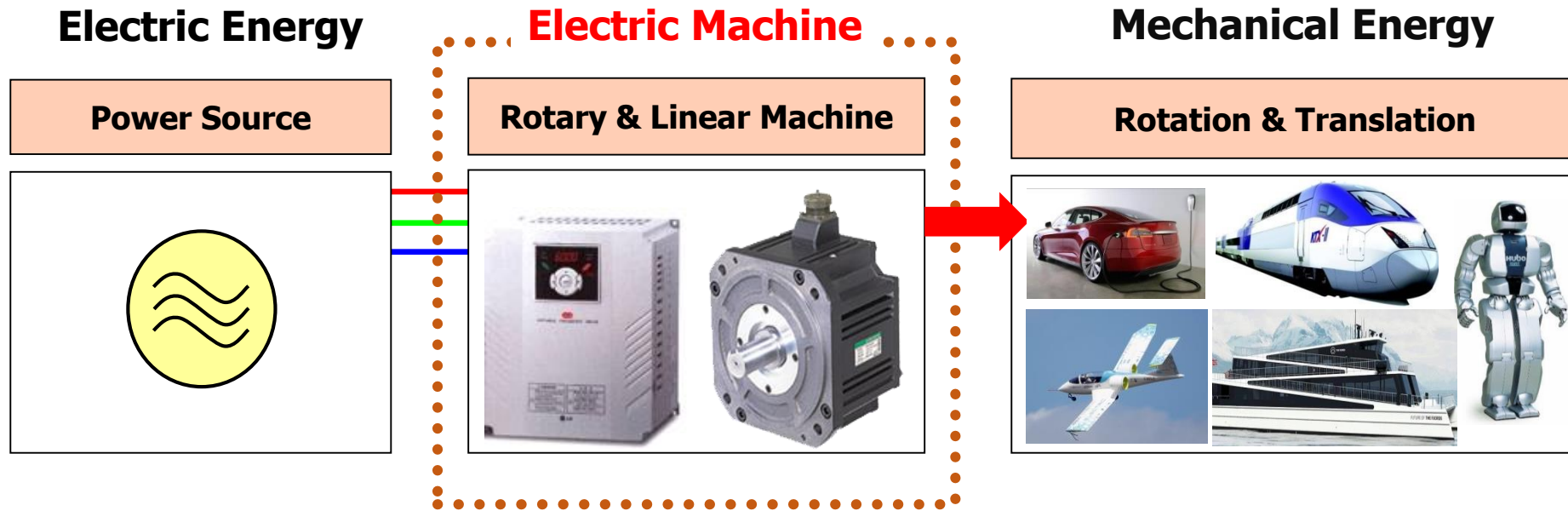

- **Ultra high power density** : Save volume / space / material
- **Ultra high efficiency** : Save energy / battery

2. VAM Patent Motor

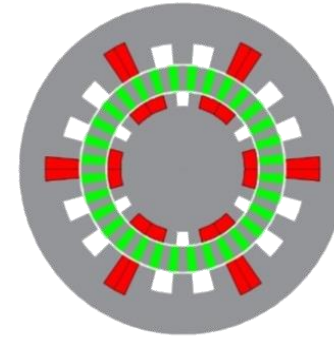

- Core
- Winding
- Permanent magnet

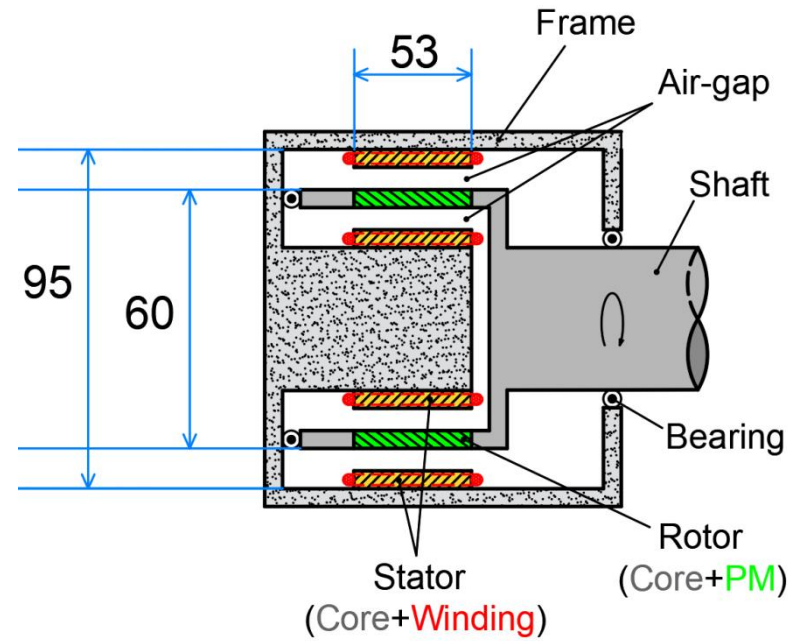

VAM Motor

(unit : mm)

3. SPM Motor vs VAM Patent Motor

- Core
- Winding
- Permanent magnet

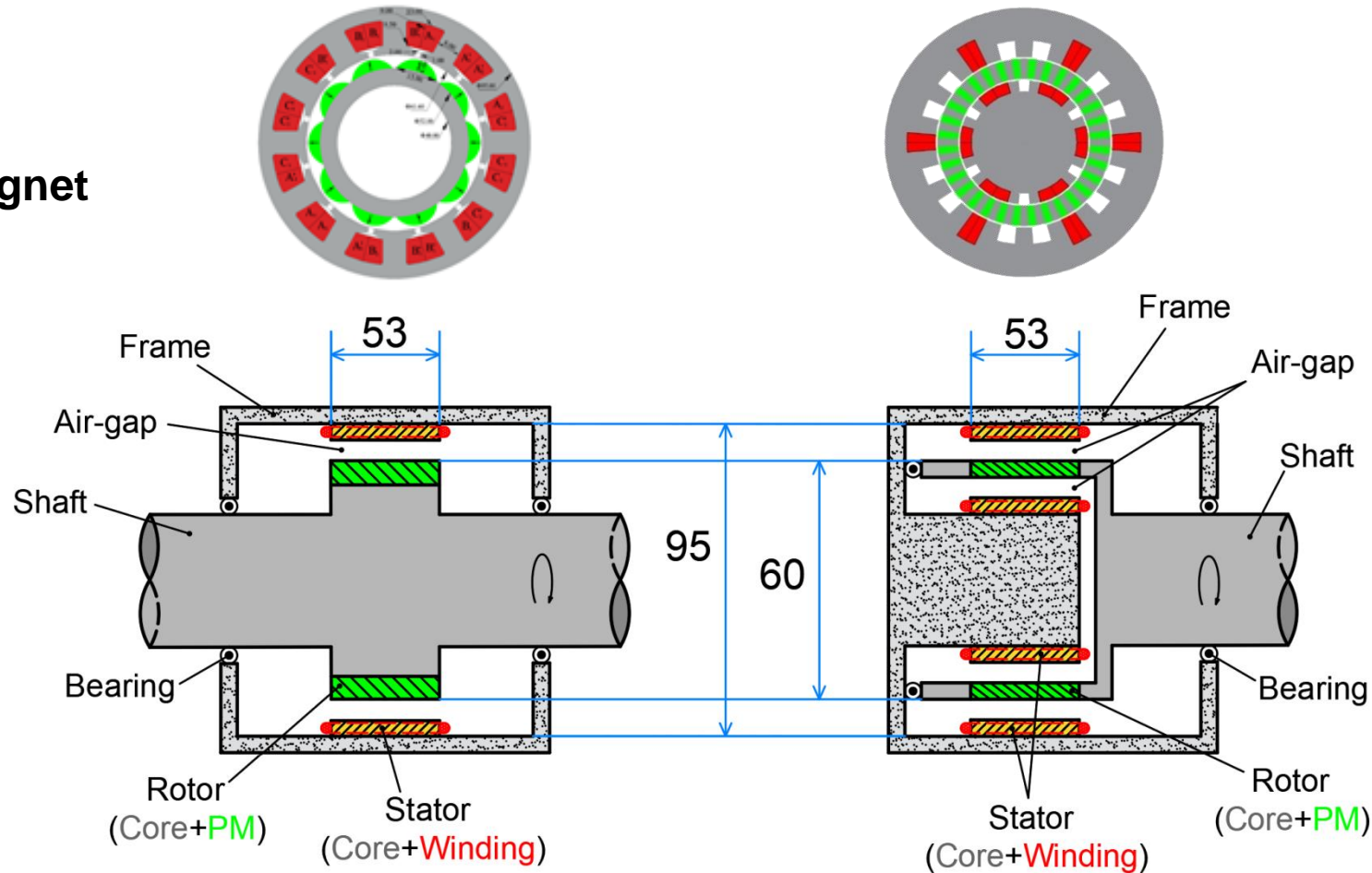

Conventional **SPM Motor**

VS

VAM Motor

(unit : mm)

*SPM Motor : Surface-mounted Permanent Magnet Motor

3. SPM Motor vs VAM Patent Motor

Speed 600 (RPM)	Frequency (Hz)	Current (kAT/m)	Output Torque (Nm)	Input (W)	Output (W)	Efficiency (%)	
Conventional SPM Motor (USA "K")	50 (10 poles)	15.81	3.04 (100%)	240.6	191	79.4	Calculation (Mech. loss 2%)
VAM Motor	140 (28 poles)	15.81*2	13.1 (430%)	931.1	825.1 (430%)	88.6 (9.2% Up)	Calculation (Mech. loss 2%)
			11.63 (383%)	851.2	732.9 (383%)	86.1% (6.7% Up)	Test (Dec. 04. 2020) Ref. IE4 V 0.75kW 600-900 RPM efficiency: 75%

VAM is doing the efforts to reach 4.2 times higher power density & 8% higher efficiency by improving production technology

4. Application

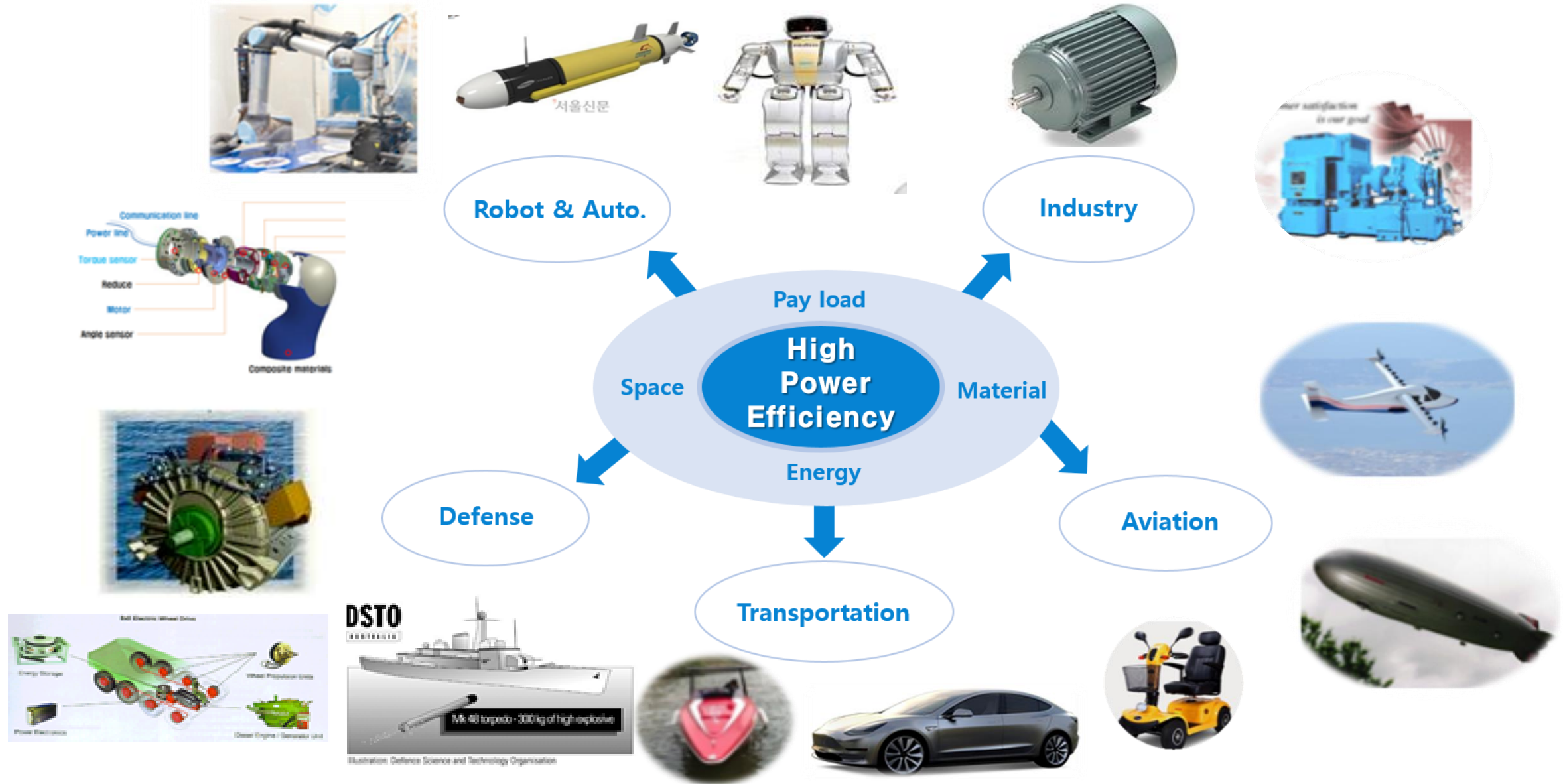

4. Application

1kW 600rpm **VAM Motor**
Efficiency **85.2%**

VAM Motor



-1kW 2400 rpm **Motor efficiency 82.7% IEC IE4V**
-600 rpm(4:1) **reduction Gear efficiency 95%**
Total Efficiency 78.6%

Conventional PM motor
+ reduction gear

